



Installation Guide

E3R-R02-3HOBP (24V)
E3R-R12-3HOBP (120V)
E3R-R24-3HOBP (240V)
E3R-R27-3HOBP (277V)

3-Wire Relay Receiver



- ILLUMRA Relay Receivers should NOT be installed in a location where the unit will be in close proximity to the light bulb(s) or other sources of heat, such as above a ceiling hugger fixture, particularly with higher wattage loads (see “Operating Temperature” on Specifications table).

Single Pole or Multi-way Wireless Switch (1 or more wireless light switches)

- Step 1: Read the CAUTION/NOTES section immediately preceding these installation options. Read all steps for this option before taking any action to install receiver.
- Step 2: **WARNING:** To avoid risk of fire, shock, or death, TURN OFF POWER at circuit breaker or fuse and verify that it is OFF before installation begins. Make sure that it remains OFF until installation is complete.
- Step 3: For in-wall installation, a wiring box must be used. For ceiling installation make wire connections inside a junction box. **Ensure that the temperature in the ceiling box will not exceed 50 degrees C (see specifications).** For best wireless signal performance install receiver in plastic box away from floor and away from metal objects.
- Step 4: Connect wires as shown in **Figure D**. Twist wire nuts on clockwise making sure no bare wires show. Wrap connections with electrical tape.
- Step 5: Restore power and follow programming instructions for appropriate programming mode (see “Programming” below). For this installation, Rocker Mode (the default programming mode) is recommended.
- Step 6: Test receiver. (If receiver is not working, review wiring and programming instructions or see “Troubleshooting” in product manual.)
- Step 7: Stow all wires and receiver in wiring box. Finish any installation of fixture or wall switch.

Programming

The receiver must be powered when programming. After programming, settings are retained when power is disconnected. The receiver sensitivity is reduced when in Learn Mode to prevent unintentionally associating unwanted transmitters with the receiver. Transmitters should be within 15 feet (5 meters) of the receiver when programming. Program the receiver in any of the modes below.

Rocker Mode (default). One side of the rocker on a wireless light switch will activate the relay (turn the light ON) when pressed and the opposite end of the same rocker will deactivate the relay (turn the light OFF) when pressed. The receiver responds only on a transmitter press and not on the release.

Momentary Mode. In Momentary Mode, each end of the rocker on a wireless light switch acts as a separate button. Each end of the rocker programs separately to 1 or more receivers. When a rocker is pressed the output on the receiver will activate (turning the electrical load ON). When the rocker is released the output will deactivate (turning the electrical load OFF).

Toggle Mode. In Toggle Mode, each end of the rocker acts as a separate button. Each end of the rocker programs separately. When the rocker is pressed the output of the receiver will always change state (if OFF, it will turn ON; if ON, it will turn OFF). The output status only changes when a button is pressed and is ignored on the release.

Follow the instructions below for the desired programming mode.

Rocker Mode (default) Programming Instructions

- Step 1: Read all Rocker Mode programming steps before taking any action to program receiver in Rocker Mode.
- Step 2: Activate Rocker Learn Mode by pressing and holding the LRN button for 1 second (See **Figure A**). The electrical load connected to the receiver will begin turning ON and OFF in a slow pattern.

- Step 3: When associating a wireless light switch with the receiver, press one end of a switch rocker (See **Figure B**). When associating a transmitter other than a wireless light switch, press the LRN or TCH button on the ILLUMRA transmitter (see appropriate transmitter starter guide). The load will stay ON for about 3 seconds indicating that the receiver has stored the transmitter’s unique ID in its memory.
- Step 4: (If only one transmitter is desired then skip Step 4 and exit Learn Mode by following Step 5). To associate a second transmitter with this receiver, wait until toggling of the load resumes. Repeat the instructions in Step 3 and Step 4 until the unique IDs of all desired transmitters (up to 30) are stored in the memory of the receiver.
- Step 5: To complete programming, just wait; the receiver automatically exits Learn Mode after 30 seconds. Alternatively, exit Learn Mode by pressing and holding the LRN button, releasing it when the load stops toggling.

Momentary Mode Programming Instructions

- Step 1: Read all Rocker Mode programming steps before taking any action to program receiver in Momentary Mode.
- Step 2: While the receiver is in Rocker Learn Mode, press and hold the LRN button for about 3 seconds (See **Figure A**). The electrical load connected to the receiver will begin turning ON and OFF in a fast pattern. The receiver is now in Momentary Learn Mode.
- Step 3: Follow steps 3-5 of “Rocker Mode Programming Instructions.”

Toggle Mode Programming Instructions

- Step 1: Read all Rocker and Momentary Mode programming steps before taking any action to program receiver in Toggle Mode.
- Step 2: While the receiver is in Momentary Learn Mode, press and hold the LRN button for about 3 seconds (See **Figure A**). The electrical load connected to the receiver will continue turning ON and OFF in a fast pattern. The receiver is now in Toggle Learn Mode.
- Step 3: Follow steps 3-5 of “Rocker Mode Programming Instructions.”

Selective Deleting. Follow the Program Mode steps above to delete a transmitter from a receiver’s memory. Upon pressing the LRN button on a transmitter (See **Rocker Mode Programming Instructions, Step 3**) which has previously been associated with the receiver, the electrical load connected to the receiver will stay OFF for 3 seconds indicating that the receiver has removed the transmitter’s unique ID from its memory.

Clear All. If the CLR button is pressed and held for 2 seconds (See **Figure C**), the entire memory of the receiver will be deleted. The receiver will instantly enter the default programming mode (Rocker Mode) indicated by the electrical load turning ON and OFF.

Automatic ON / Automatic OFF. If the receiver learns a wireless motion sensor, the load will turn OFF after no occupancy has been detected for 15 minutes. If learned in the Rocker Mode, the output will be Manual ON / Automatic OFF. If learned in Momentary Mode, the output will be Automatic ON / Automatic OFF.

Additional Programming Options

Inverted Output Mode. The receiver supports the Inverted Output Mode of operation. In the default configuration, the N.O. relay contact is open (not connected) when not active, and closed (connected) when active. When the outputs are in Inverted Output Mode, the N.O. contact is closed when not active and open when active. Inverting the outputs may be used to emulate a normally closed relay that opens when a switch is activated.

One common use for this mode is for magnetic door release controls. The output is ON and the door-hold electromagnet is active until a Momentary switch is activated, deactivating the electromagnet and allowing the door to close. The magnet is reactivated as soon as the switch is released.

Overview

The 3-Wire Relay Receiver provides fast and simple installation of remote controls for lighting and other loads. The receiver responds to radio signals from self-powered wireless light switches and other compatible transmitters. The receiver mounts in ceiling junction boxes, wall switch boxes, and wiring cavities.

Compatible Devices

- Single Rocker Self-powered Wireless Light Switch; E3T-S1Axx
- Dual Rocker Self-powered Wireless Light Switch; E3T-S2Axx
- Handheld Self-powered Wireless Light Switch; E3T-S2Hxx
- Key Card Access Switch; E3T-C1AWH
- SLT Wireless Sensor; E3T-Rxx-2INBP
- Self-powered Wireless Occupancy Sensor; E3T-Mxx-SB24
- More transmitters available

Components Included

The following items are included with this product:

- A -- (1) ILLUMRA 3-wire Relay Receiver

Tools Needed for Installation

- Pencil or ball point pen
- Electrical tape
- Wire nuts

Installation

To install the 3-wire Relay Receiver, follow the instructions. For transmitter installation instructions, see appropriate installation guide(s).

CAUTION/NOTES:

- Depending on the circumstances, it may be convenient to pre-program the receiver prior to final installation.
- Always follow local electrical codes when installing this device. Installation should be performed by a qualified electrician.
- ILLUMRA Relay Receivers are intended only for use indoors, in dry locations, and with permanently installed fixtures.

Inverted Output Mode Programming Instructions

- Step 1: Turn the power to the receiver OFF.
- Step 2: Press and hold the CLR button for about 5 seconds while turning on the power. The load will blink twice to indicate activation of Inverted Output Mode.

To change back to normal operating mode, repeat Steps 1 and 2. The load will blink once to indicate normal (non-Inverted) mode. The state of this mode is stored in non-volatile memory and is maintained even if the power is removed.

Specifications

		E3R-R02-3HOBP	E3R-R12-3HOBP	E3R-R24-3HOBP	E3R-R27-3HOBP
Range		50-150 feet (typical)			
Frequency		315 MHz			
Relay Output		24 VAC	120 VAC	240 VAC	277 VAC
Max Loads/ Contact Ratings	Tungsten / Incandescent	100 W	500 W	1000 W	1150 W
	Fluorescent Ballast	3 A			
	General Duty	6 A			
	A300 Pilot Duty	24 VA	120 VA	240 VA	277 VA
Power Supply		24 VAC 50/60 Hz	120 VAC 50/60 Hz	240 VAC 50/60 Hz	277 VAC 50/60 Hz
Output Channels		1 FORM A Relay			
Memory		Stores up to 30 switch IDs			
Dimensions		2.11 x 1.73 x 1.09 inches (54 x 44 x 28 mm)			
Operating Temperature		14° to +122°F (-10° to +50°C)			
Storage Temperature		-4° to +176°F (-20° to +80°C)			
Radio Certification		FCC (United States): SZV-TCM2XXC I.C. (Canada): 5713A-TCM2XXC			
Safety Approval		ETL (U.S.): UL244A ETL (Canada): CSAc22.2#14-05			

Diagrams

Figure A: Enter Learn Mode

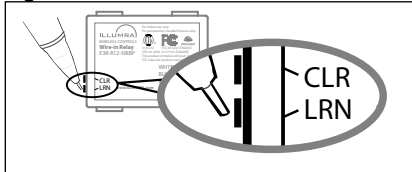

Figure B: Press Transmitter

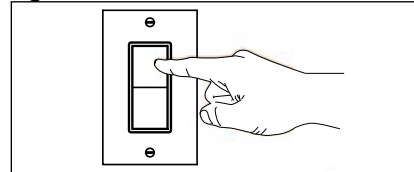

Figure C: Clear All

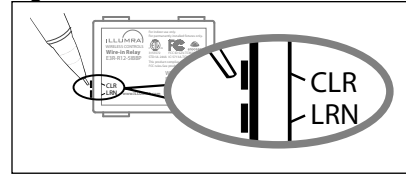
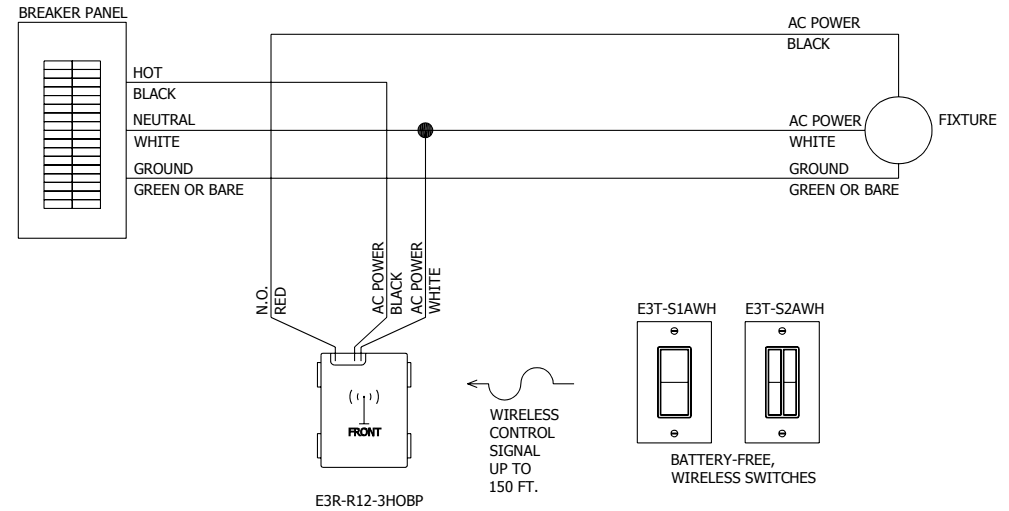

Figure D: Single Pole or Multi-way Wireless Switch (1 or more wireless light switches)



Contains FCC ID: SZV-TCM2XXC
Contains IC: 5713A-TCM2XXC

The enclosed device complies with Part 15 of the FCC Rules. Operation is subject to the following two conditions: (i) this device may not cause harmful interference and (ii) this device must accept any interference received, including interference that may cause undesired operation.



ETL (US) – Conforms to UL STD 244A. This device was tested according to and was found to comply with UL 244A Solid State Controls for Appliances.

ETL (Canada) – Certified to CAN/CSA STD C22.2 No. 14-05. This device was tested according to and was found to comply with CAN/CSA STD C22.2 No. 14-05.

This device or certain aspects thereof is protected by at least one U.S. or international patent or has at least one such patent application pending.



ILLUMRA is a trademark of Ad Hoc Electronics, LLC. Other trademarks herein are the property of their respective owners.

AHD0227B